

**MODEL-ORIENTED DECISION SUPPORT SYSTEM
AND FUZZY INFORMATION PROCESSING
FOR INCREASING EFFICIENCY OF UNIVERSITY
– IT-COMPANY CONSORTIA**

Yuriy P. Kondratenko, Galyna V. Kondratenko, Ievgen V. Sidenko

Department of Intelligent Information Systems
Petro Mohyla Black Sea State University, Mykolaiv, Ukraine
e-mail: y_kondrat2002@yahoo.com, galvlad09@rambler.ru, emoty@mail.ru

Vyacheslav S. Kharchenko

Department of Computer Systems and Networks
National Aerospace University “KhAI”, Kharkiv, Ukraine
e-mail: v_s_kharchenko@ukr.net

Abstract: In the paper the existing approaches for improving abovementioned collaboration processes, technologies and methodologies based on efficient methods of optimization and decision making, modern computer-based systems and Internet opportunities are been discussed. The main contribution of the authors in this paper is a structure of computerized decision making system (CDMS) which can help partners from education and industry to find the best model of university – IT-company consortia from proposed set of efficient models A1, A2, B, C and their rational combinations.

Keywords: decision support system, fuzzy logic, linguistic model, membership function, linguistic term, rule base, fuzzyfication, defuzzyfication, university – IT-company consortium

INTRODUCTION

The essential influence on the general development and integration level of informational technologies into Ukrainian or any national economy and into world market's segments is done by results of high-efficiency and mutually profitable cooperation of universities and IT-companies. Herein implementation of the new models of cooperation requires consideration and preliminary

processing of large amount of input data, in particular, based on analysis of preliminary cooperation experience of involved parties, their main achievements, competitiveness, advantages and directions for the development, scientific and educational levels of participants of future academic-industrial consortium, employment level of students, university professors and IT-companies, etc. Incorrectly chosen model of cooperation as well as non observation of relevant conditions of collaboration within the consortium such as "University – IT-companies" can lead to undesired and unexpected consequences, including the loss of significant amount of intellectual and/or material resources, lowering educational-qualification level of specialists, appearing of limitation in education and development of ability to creative thinking [Kharchenko and Sklyar 2014, Kondratenko and Kharchenko 2014, Kondratenko 2011].

THE STATEMENT OF RESEARCHED PROBLEM

Increase of cooperation efficiency can be influenced by model-oriented decision support systems (DSS), which is developed on the basis of the latest methods, technologies, and approaches of system analysis, forecasting, fuzzy logics, neural networks, artificial intelligence, etc. [Kazymyr et al. 2015, Lytvynov et al. 2015]. Usage of the above mentioned methods when designing modern DSS allows to process the essential amount of different-type information on a new level of intellectual cooperation of a decision maker (DM) and computer system [Chrzanowska and Chudzian 2014, Gaspars-Wieloch 2014, Rotshtein 1999, Zadeh 1965]. Nowadays there is still an unsolved question of selecting partnership models based on developing the system of multicriterion assessment of possible level of cooperation between universities and IT-companies. Usage of such class DSS in some specific practical cases makes it possible to select the best variant of the model of consortia development such as "University – IT-company" [Kondratenko and Kharchenko 2014, Starov et al. 2014].

The aim of this work is development and research model-oriented DSS based on fuzzy logic to increase the efficiency of multicriterion decision making processes for choosing a model of cooperation within consortia such as "University – IT-company".

Preliminary researches and analysis of successful cooperation experience within different-type consortia prove that nowadays solving the task of estimating the level of cooperation between universities and IT-companies involves the selection of one of the four formed alternative models [Kharchenko and Sklyar 2014] as alternative decision variants $E_i, (i=1..4)$, where decision variant E_1 corresponds to the model A1 (cooperation between university and IT-company in the sphere of education and study organization, knowledge sharing, targeted personnel training for IT-industry); variant E_2 – model A2 (organization and

support of certification processes of cooperation results); variant E_3 – model B (creating collective center of scientific researches, developing collective scientific projects); variant E_4 – model C (creation of student research groups with business orientation and realization of startups). Herein the efficiency of process of selecting cooperation model essentially depends on chosen criterion x_j , ($j=1,2,\dots,n$), which characterize each partner of the relevant future consortium such as "University – IT-company". Usage of fuzzy logics and hierarchical structure of input data (coordinates) when developing model-oriented DSS of such type allows to increase efficiency of multicriterion selection of cooperation model between universities and IT-companies, which is achieved by simplifying the process of formation and processing knowledge, taking into account significant amount of quality indicators and selection of optimal solution for a large amount of input expert information [Kondratenko et al. 2011, Rotshtein 1999, Zadeh 1965].

THE ANALYSIS OF RESEARCHING INTELLECTUAL DSS WITH HIERARCHICALLY-ORGANIZED STRUCTURE

In this study there is considered the developed by Authors model-oriented DSS for selecting model ($m=4$) of cooperation between universities and IT-companies according to preliminary proposed and defined criterion ($n=27$). The experience of professionals in the sphere of designing specialized fuzzy system of different purpose shows that with one-level structure of DSS in cases of large dimension of input coordinates vector $X = \{x_j\}, j=1..n$ sensitivity of their fuzzy rule bases to changes of input coordinates (criterion) values reduces $x_j, (j=1,2,\dots,n)$ [Kondratenko and Kondratenko 2014, Kondratenko and Sidenko 2014]. This is primarily due to complexity of creating relevant fuzzy rules to realize all possible dependences between input and output parameters of the system $y_k = f(x_1, x_2, \dots, x_{27}), k=1..K$.

Let's describe all linguistic variables in the model structure (Figure 1): x_1 – level of scientific novelty of projects; x_2 – practical significance of projects; x_3 – accordance to study direction; x_4 – work experience in IT-sphere; x_5 – participation in international programs of students exchange; x_6 – level of students cooperation with IT-companies; x_7 – success in study; x_8 – level of innovative projects; x_9 – number of patents; x_{10} – number of grants; x_{11} – level of scientific publications in university department; x_{12} – number of scientific publications in university department; x_{13} – university category; x_{14} – IT-certification of department teachers; x_{15} – number of business courses; x_{16} – experience in organizing student companies; x_{17} – experience in organizing mixed creative teams

for execution and realization of IT-projects; x_{18} – level of knowledge transfer of IT staff considering their employment; x_{19} – experience level of IT company personnel; x_{20} – educational qualification level of IT company personnel; x_{21} – experience of IT company in supporting the development of innovative researches; x_{22} – experience of cooperation with universities; x_{23} – age of IT-company; x_{24} – potential of university department for cooperation; x_{25} – potential of IT-company for cooperation; x_{26} – expected results for the university department, x_{27} – expected results for the IT company; y_1 – evaluation level of diploma/master's work; y_2 – level of professional students orientation; y_3 – level of scientific activity of the university department; y_4 – level of business orientation of the university department; y_5 – assessment of a possible knowledge exchange of IT-company staff; y_6 – assessment of a possible level of scientific and educational support from the IT-company; y_7 – possibility of cooperation; y_8 – general educational level of students; y_9 – general activity level of the university department; y_{10} – general activity level of IT-company; y – cooperation level under consortia such as "University – IT-company".

In Figure 1 there is shown the variant of proposed by Authors hierarchically-organized DSS St_s to select the best model E^* , ($E^* \in E, E = \{E_1, E_2, E_3, E_4\}$) of cooperation between universities and IT-companies, which is created on the basis of input coordinates vector decomposition $X = \{x_j\}, j=1...27$ with their association in the next s -group combination (1):

$$X_s = \left\{ \begin{array}{l} \{x_1, x_2, x_3\}, \{x_4, x_5, x_6, x_7\}, \{x_8, x_9, \dots, x_{13}\}, \{x_{14}, x_{15}, x_{16}, x_{17}\}, \\ \{x_{18}, x_{19}, x_{20}, x_{21}, x_{22}, x_{23}\}, \{x_{24}, x_{25}, x_{26}, x_{27}\} \end{array} \right\} \quad (1)$$

Herein, corresponding subsystems of DSS (Figure 1), among them $\{FES_1, FES_2, \dots, FES_{10}, FES_{11}\}$, realize next functional dependencies for s alternative structure $St_s = \{y_1, y_2, \dots, y_{10}, y\}$ of DSS (2):

$$St_s = \left\{ \begin{array}{l} y_1 = f_1(x_1, x_2, x_3), y_2 = f_2(x_4, x_5, x_6, x_7), y_3 = f_3(x_8, x_9, \dots, x_{13}), \\ y_4 = f_4(x_{14}, x_{15}, x_{16}, x_{17}), y_5 = f_5(x_{18}, x_{19}, x_{20}, x_{21}, x_{22}, x_{23}), y_6 = f_6(x_{18}, x_{19}, \dots, x_{23}), \\ y_7 = f_7(x_{24}, x_{25}, x_{26}, x_{27}), y_8 = f_8(y_1, y_2), y_9 = f_9(y_3, y_4), \\ y_{10} = f_{10}(y_5, y_6), y = f_{11}(y_7, y_8, y_9, y_{10}) \end{array} \right\} \quad (2)$$

Figure 1. The structure of hierarchical DSS based on fuzzy logics for selecting model of cooperation within consortia such as "University – IT-company"

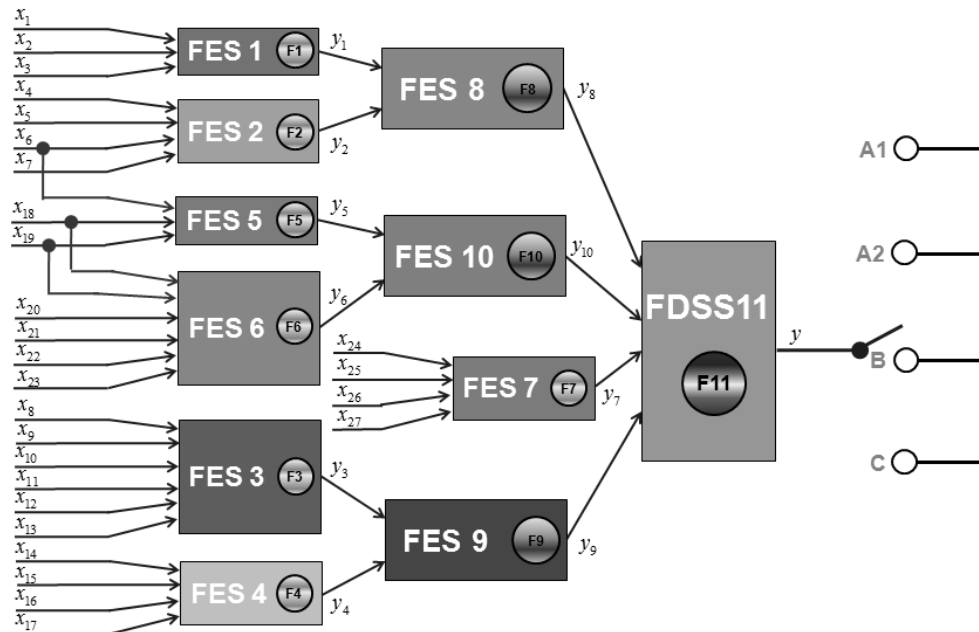

Source: own elaboration

Fuzzy DSS with the corresponding alternative structure St_s (Figure 1) evaluates the possible level of cooperation by 4 models (A1, A2, B, C). To change (increase or decrease) the number of evaluation models it necessary to change the number of linguistic terms of output variable in the eleventh subsystem $y = f_{11}(y_7, y_8, y_9, y_{10})$, and accordingly to correct the rule base of the eleventh subsystem. For example, for evaluation of the level of cooperation by 7 models (A1, A1-A2, A2, A2-B, B, B-C, C), where A1-A2, A2-B, B-C are combined models, it necessary to increase the number of linguistic terms of output variable to 7 (“Very Low” – VL, “Low” – L, “Lower than Medium” – L, “Medium” – M, “Higher than Medium” – M, “High” – H, “Very High” – VH).

So, for example, the second subsystem $y_2 = f_2(x_4, x_5, x_6, x_7)$ for assessment of level of professional orientation of students in relevant university is being created (Figure 1) on the basis of four input coordinates (x_4 – experience of work in IT-sphere: the range of change – [0 100], x_5 – participation in international programs of students exchange: the range of change – [0 100], x_6 – level of students cooperation with IT-companies: the range of change – [0 100], x_7 – success in study: the range of change – [60 100]), which are combined according to

common abilities, and one output coordinate (y_2 – level of professional students orientation: the range of change – [0 100]) with realization of relevant knowledge base, which includes 81 fuzzy rules of productional type (Table 1). To design fuzzy rule bases for developed structure of DSS (Figure 1) there are used linguistic terms $\{Low, Medium, High\}$ with triangular shape of membership function [Kondratenko and Sidenko 2011], [Zadeh 1965]. Graphical representation of possible values of variables x_4, x_5, x_6, x_7, y_2 and their relation to linguistic terms are represented in Figure 2.

Figure 2. Linguistic terms for variables x_4, x_5, x_6, y_2 (a) and x_7 (b)

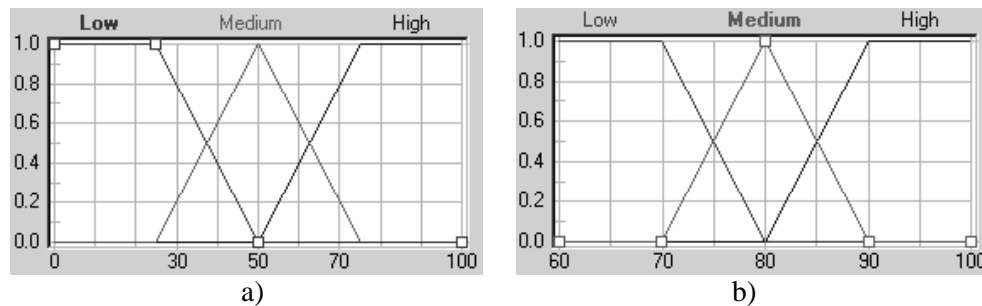

Source: own elaboration

The function structure $f_2(x_4, x_5, x_6, x_7)$, which is realized through the corresponding fuzzy inference engine, consists of fuzzyfication of input variables x_4, x_5, x_6, x_7 , activation of rules, aggregation of antecedent components of corresponding rules based on *MIN* operation, accumulation of consequents and formation of the resulting fuzzy set. Defuzzyfication procedure using the center of area method (Fast CoA) applicable only to the output variable y in the eleventh subsystem $y = f_{11}(y_7, y_8, y_9, y_{10})$.

Double-sided fuzzyfication/defuzzyfication procedure is performed mainly in single-level (non-hierarchical) fuzzy systems. In a hierarchically-organized systems fuzzyfication procedure is performed for input variables in all subsystems, and defuzzyfication procedure – only for output variable in the subsystem of the last hierarchical level (in our case, for the eleventh subsystem $y = f_{11}(y_7, y_8, y_9, y_{10})$). At the intermediate levels defuzzyfication procedure is not performed. Result of the fuzzy logic inference engine in the form of resulting fuzzy set directly transmitted to the fuzzy logic inference engine of the next hierarchical level. This allows decreasing the calculation time of output variable.

Table 1. Selective ruleset of knowledge base of the second subsystem

Number of rule	x_4	x_5	x_6	x_7	y_2
1	Low	Low	Low	Low	Low
2	Low	Low	Low	Medium	Low
3	Low	Low	Low	High	Low
... ..					
37	Medium	Medium	Low	Low	Low
38	Medium	Medium	Low	Medium	Medium
39	Medium	Medium	Low	High	Medium
... ..					
76	High	High	Medium	Low	Medium
77	High	High	Medium	Medium	Medium
78	High	High	Medium	High	High
79	High	High	High	Low	Medium
80	High	High	High	Medium	High
81	High	High	High	High	High

Source: own elaboration

Human-computer interface of CDMS, program realization and results of DSS work for selecting the model of cooperation within consortia such as "University – IT-company" are shown on Figure 3. For the presented on Figure 3 set of input data $X = \{x_j\}, j=1...27$ developed DSS on fuzzy logics (Figure 1) creates on its output consolidated signal, which recommends corresponding future partners for cooperation (specific University and specific IT-company) to choose as optimal model E^* the model of cooperation B : $E^* = B, (E^* \in E, E = \{E_1 = A1, A2, B, C\})$.

As input data for modular DSS different-type input variables $X = \{x_j\}, j=1...27$ are used, which characterize performance indicators of university (of relevant IT-department) and IT-companies, which are part of academic-industrial consortia. Some of input data are quantitative, and some – qualitative. Quantitative input indicators can be created on the basis of results of statistical information processing [Binderman, Borkowski and Szczesny 2011], and qualitative – on the basis of results of expert evaluations (using individual and group assessments) [Gil-Aluja 1999, Gil-Lafuente and Merigo 2010, Kondratenko and Kondratenko 2014, Lodwick and Kacprzych 2010].

The working efficiency of the developed hierarchically-organized DSS based on fuzzy logic for selecting the model of cooperation within consortia such as "University – IT-company" tested on the different types of sets of the input data, that were received from specific universities and IT-companies, that corresponding to the possible models of cooperation.

Figure 3. The interface of developed model-oriented DSS for selecting the model of cooperation within consortia such as "University – IT-company"

The screenshot displays the 'UIC_Model' software interface. It features 11 'Fuzzy DSS' panels (F1-F11) for inputting data. Each panel contains numerical values and 'Inverse'/'NI' checkboxes. A 'Calculate' button is located in the center. The bottom section shows the results: 'Evaluation of UIC-model (y) 72.3' and 'UIC-model B', with 'B' circled and labeled 'Model B'.

Source: own calculations

Practical usage of the developed fuzzy DSS to for selecting the model of cooperation within consortia such as "University – IT-company" tested in successful cooperation of Petro Mohyla Black Sea State University (PMBSSU), Ukraine and following IT-companies:

- Global Logic Ukraine, cooperation since 2010 (model A1);
- Template Monster, cooperation during 2008 - 2010 (Model C);
- D-Link, cooperation since 2010 (model A2);
- Camo IT, cooperation since 2015 (model B).

CONCLUSIONS

In this paper there are shown results of developing hierarchically-organized DSS, which is synthesized on the basis of using fuzzy logics, to increase efficiency of decision-making processes for selecting optimal model E^* of partner cooperation under consortia such as "University – IT-company". Made by authors analysis of samples of successful innovative cooperation of academic institutions and IT-companies [Kharchenko and Sklyar 2014], [Kondratenko and Kharchenko 2014], [Kondratenko 2011] proves that creation of different groups, consortia, associations and alliances such as "University – IT-company" to solve current and future problems in higher education sphere based on mutual working experience in computer science area and internet-communications is a perspective direction in

the area of improving efficiency of higher education system. In particular, the National Aerocosmic University “Kharkiv Aviation Institute” named after M. E. Zhukovskiy, Odessa National Polytechnic University, Yuriy Fedkovych Chernivtsi National University, Chernihiv State University, Petro Mohyla Black Sea State University, Institute of Cybernetics of National Academy of Sciences of Ukraine and others are members of such international academic-industrial consortia, which includes universities and IT-companies from Great Britain, Spain, Italy, Portugal, Ukraine and Sweden [Kharchenko and Sklyar 2014]. This consortium is created to develop and implement models of cooperation between universities and industry (IT-companies) such as A1, A2, B and C within the project TEMPUS-CABRIOLET 544497-TEMPUS-1-2013-1-UK-TEMPUS-JPHES “Model-oriented approach and Intelligent Knowledge-Based System for Evolvable Academia-Industry Cooperation in Electronics and Computer Engineering” (2013-2016).

Aprobation of the developed model-oriented DSS proves its high efficiency, that is confirmed by authors as in solving practical tasks of selecting a model of cooperation within consortia such as "University – IT-company", and in solving different-type tasks of transport logistics [Kondratenko et al. 2006], [Kondratenko and Sidenko 2014], in particular when selecting the best transport company from the set of existing alternative variants, etc.

REFERENCES

- Binderman Z., Borkowski B., Szczesny W. (2011) An Application of Radar Charts to Geometrical Measures of Structures' of Conformability, *Quantitative Methods in Economics*, Vol. XII, No. 1, pp. 1-13.
- Chrzanowska M., Chudzian J. (2014) Application of Regression Models in Analysis of the Advertisement's Impact on Consumer's Decision Making Process, *Quantitative Methods in Economics*, Vol. XV, No. 2, pp. 64-73.
- Gaspars-Wieloch H. (2014) Modifications of the Maximin Joy Criterion for Decision Making Under Uncertainty, *Quantitative Methods in Economics*, Vol. XV, No. 2, pp. 84-93.
- Gil-Aluja J. (1999) *Investment in Uncertainty*, Kluwer Academic Publishers, Dordrecht, Boston, London.
- Gil-Lafuente A. M., Merigo J. M. (2010) Decision Making Techniques in Political Management [in book] *Fuzzy Optimization. Studies in Fuzziness and Soft Computing* 254, Lodwick, W. A., Kacprzych, J. (Eds), Springer-Verlag, Berlin, Heidelberg, pp. 389-405.
- Kazymyr V. V., Sklyar V. V., Lytvyn S. V., Lytvynov V. V. (2015) *Communications Management for Academia-Industry Cooperation in IT-Engineering: Training/ V.S.Kharchenko (Ed.)*, Chernigiv-Kharkiv: MESU, ChNTU, NASU “KhAI”.
- Kharchenko V. S., Sklyar V. V. (2014) Cooperation Between Universities and IT-Industry: Some Problems and Solutions, *Kartblansh*, No. 3-4, pp. 43-50.

- Kondratenko G. V., Sidenko Ie. V., Chekashova O. V. (2011) Features Synthesis of Fuzzy Hierarchical DSS in the Environment FuzzyTECH, Materials of Intern. Scientific-practic. Conf. "Olvia Forum - 2011", Yalta, Ukraine, June 2011, pp. 36-36.
- Kondratenko G. V., Kondratenko Y. P., Romanov D. O. (2006) Fuzzy Models for Capacitive Vehicle Routing Problem in Uncertainty, Proc. 17th International DAAAM Symposium "Intelligent Manufacturing and Automation: Focus on Mechatronics & Robotics", Vienna, Austria, pp. 205-206.
- Kondratenko Y., Kondratenko V. (2014) Soft Computing Algorithm for Arithmetic Multiplication of Fuzzy Sets Based on Universal Analytic Models, [in book] Information and Communication Technologies in Education, Research, and Industrial Application. Communications in Computer and Information Science, Springer International Publishing Switzerland, pp. 49-77.
- Kondratenko Y., Kharchenko V. (2014) Analysis of Features of Innovative Collaboration of Academic Institutions and IT-Companies in Areas S2B and B2S, Technical news, No. 1(39), pp. 15-19.
- Kondratenko Y. P., Sidenko Ie. V. (2011) Features Synthesis and Modeling of Hierarchically-Organized DSS Based on Fuzzy Logic, Journal of the Kherson National Technical University, No. 2(41), pp. 150-158.
- Kondratenko Y. P. (2011) The Role of Inter-University Consortia for Improving Higher Education System, Proceedings of Phi Beta Delta (Ed. by Michael Smithee), Honor Society for International Scholars, USA, May 2011, Vol. 2, No. 1, pp. 26-27.
- Kondratenko Y. P., Sidenko Ie. V. (2014) Design and Reconfiguration of Intelligent Knowledge-Based System for Fuzzy Multi-Criterion Decision Making in Transport Logistics, Journal of Computational Optimization in Economics and Finance, Vol. 6, Issue 3, pp. 229-242.
- Lodwick, W. A., Kacprzych, J. (Eds) (2010) Fuzzy Optimization. Studies in Fuzziness and Soft Computing 254, Springer-Verlag, Berlin, Heidelberg.
- Lytvynov V. V., Kharchenko V. S., Lytvyn S. V., Saveliev M. V., Trunova E. V., Skiter I. S. (2015) Tool-Based Support of University-Industry Cooperation in IT-Engineering. Chernigiv, ChNTU.
- Rotshtein A. P. (1999) Intelligent Technologies of Identification: Fuzzy Logic, Genetic Algorithms, Neural Networks. Universum Press.
- Starov O., Sklyar V., Kharchenko V., Boyarchuk A., Phillips C. (2014) A Student-in-the-Middle Approach for Successful University and Business Cooperation in IT, Proceedings of the University-Industry Interaction Conference, Barcelona, Spain, April 2014, pp. 193-207.
- Zadeh L. A. (1965) Fuzzy sets, Information and Control, No. 8(3), pp. 338-353.